

Group 24/03

Pressure Regulators 36 x 32 mm

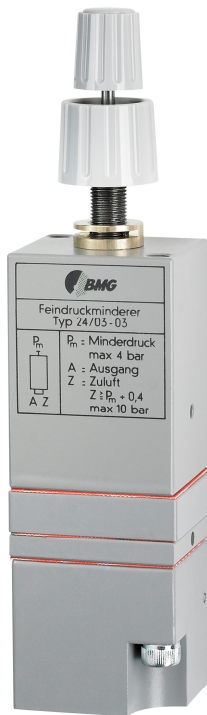

Type 24/03 – 03



Type 24/03 – 05

The pressure regulators are reducing valve for compressed air and inert gases. They distinguish themselves by the constancy of the downstream pressure, which is maintained within fixed limits independent on upstream pressure variations and flow changes.

The set point of the pressure to be measured (downstream pressure) can be set by hand. As to type 24/03-03 the set point can be particularly fine-tuned means of a double control button.

Characteristics

- Great constancy of the downstream pressure
- High responsiveness
- Small space required and low weight
- Maintenance-free service
- Long durability

Application

The instrument can be used, where an exact and continuous pressure is necessary in spite of changing consumption of the pressure medium. The pressure regulators are used as:

- set point transmitter for pneumatic controllers
- remote adjustor for control elements with pneumatic motor (e.g. diaphragm valves)
- pressure transmitter in pneumatic test benches for measuring and control instruments as well as for density tests
- supply-air provision for control installations, pneumatic gauging devices, tool machine controls, pneumatic band control etc.
- supply-air and overflow controller for the overloading pressure at pressure tanks

The instrument type 24/03-03 with the additional precision adjustment (lens effect) is particularly suitable as pressure controller of pneumatic testers, for pressure gauges with fine tuning, controllers and relays.

Functioning Method

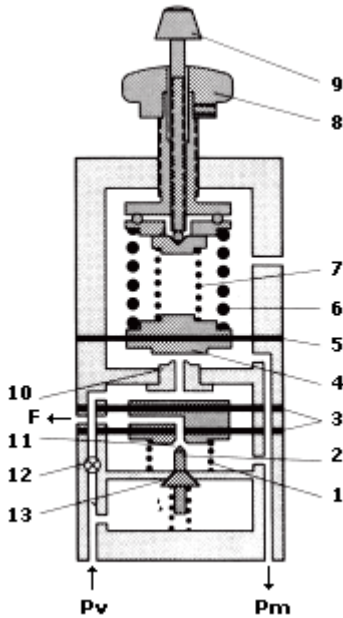

Type 24/03-03

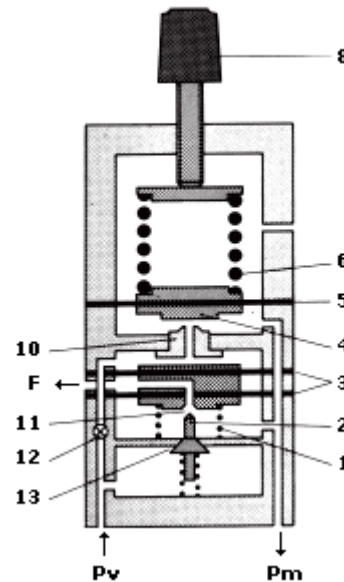

Type 24/03-05

The pressure regulator is a proportional controller with very small P-range, which forces the high constancy of the downstream pressure. The diaphragm (5) compares the forces of set point and actual value of the pressure to be measured. The set point is with type 24/03-05 the force of the spring (6), with type 24/03-03 the force sum of the springs (6) and (7).

The P-range is so small, because for the full control of the nozzle (10) only minimum ways of the flapper (4) resp. diaphragm (5) and thus of the springs are necessary.

The high responsiveness of the nozzle-flapper system and the great independence of the downstream pressure on upstream variations or flow changes is to be attributed to the constant pressure drop at the nozzle (10). This pressure drop is caused by the spring (1), which maintains a continuous difference between the pressure over the double diaphragm (3) and the downstream pressure p_m . The differential pressure is equal to the quotient of the force of the spring (1) and the effective surface of the double diaphragm (3).

If the downstream pressure (p_m) decreases by a rise of the air flow or by a drop of the upstream pressure (p_v), or if the set point is raised, the diaphragm (5) and thus the flapper (4) moves downwards. The nozzle (10) is more covered. The pressure in the chamber over the double diaphragm (3) rises, as air flows into the chamber through the throttle (12). Thereby the double diaphragm (3) and the outlet seat (11) are pushed downwards. The double cone (2) closed the outlet seat (11) and opens the inlet seat (13). The previous deviation is compensated.

Technical Data

	Group 24/03
Admissible temperature:	-20 to 60°C (minus temperatures only for dry and cleaned air or inert gases)
Consumption:	0.002 to 0.2 Nm ³ /h dependent on the upstream pressure
Constancy of the downstream Pressure:	within ± 10 mm WC at 1 lp/cm ² Upstream pressure variation + 40 mm WC at 100 NI/h Reception change
Materials:	Housing of zinc-casting Smaller parts of brass and stainless steel Diaphragm of special rubber tissue-reinforced Colour of the instrument dust-grey, RAL 7037, silk-dull
Connections:	threaded holes M 10 x 1 with screwed pipe joints as per DIN 2353 for metal or plastic tube Ø 6 x 1 mm
Weights:	type 24/03-05 0.5 kg type 24/03-03 0.8 kg
Dimensions:	see dimensional drawings

Dimensional drawing (dimension in mm)

Dimensional drawing Type 24/03-05
front view (incorporated) side view (attached)

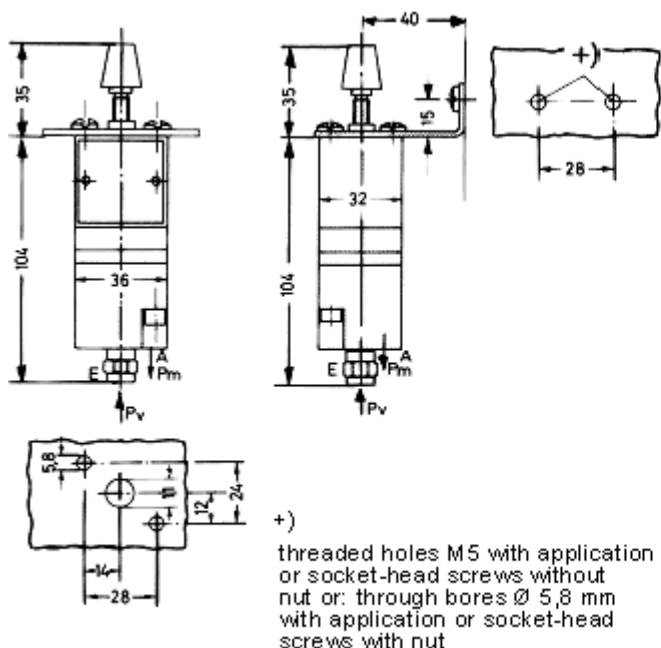

Dimensional drawing Type 24/03-03
front view (incorporated) side view (attached)

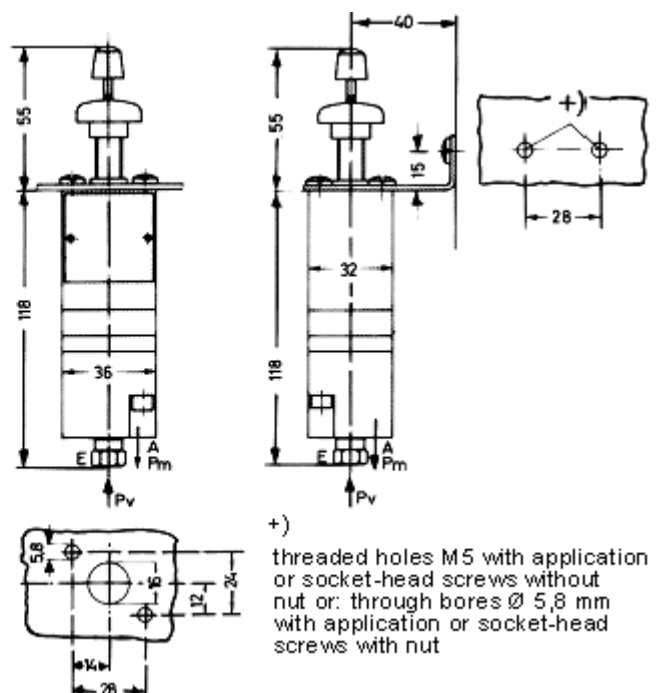

Instrument types

Types	upstream pressure Pv in kp/cm^2		downstream pressure Pm in kp/cm^2 output A	Flow C in Nm^3/h
	max. Pv	min. Pv		
24/03 - 05			0,1 to 4,0	Approx. $1,2 \times P_m$ (Pm in kp/cm^2)
24/03 - 03	10	$P_v > P_m + 0,4$	0,02 to 4,0	

Order Text

Pressure regulator 36 x 32 mm

Type 24/03- ... (see „Technical data“)

Right of modifications reserved